

PARTS LIST			
ITEM	QTY	PART NUMBER	DESCRIPTION
1	1	ABA-PUMP-1-BODY	One Gallon Pump Body
2	1	ABA-80-GCV-MAN-B	One Gallon Pump Bottom Manifold with Gravity Check Valves
3	1	ABA-80-GCV-MAN-T	One Gallon Pump Top Manifold with Gravity Check Valves
00728	1	ABA-85-47	1 Gallon Pump Saddle
73	1	ABA-425-42G RevA	Flag, Sensor Prox Pump Turret
74	1	ABA-425-42F RevB	Bracket, Prox Pump, 18mm
78	2	ABA-BRKT-0148	Pump Bracket
80	1	ABA-BRKT-013 RevB	1 Gallon Pump Mounting Bracket
82	1	ABA-85-77-RevB	One Gallon Pump Turret Guard
83	1	ABA-85-50	Pump Guard

		UNLESS OTHERWISE SPECIFIED DIMENSIONS ARE IN INCHES TOLERANCES: ANGULAR: MACH ±0.5° BEND ±1° THREE PLACE DECIMAL ±.005" TWO PLACE DECIMAL ±.01" ONE PLACE DECIMAL ±.1" INTEGER (NO DECIMAL) ±.1" FRACTIONAL ± 1/32" HOLES: Ø 0 - .125 +.004/-0.002 Ø .126 - .25 +.006/-0.003 Ø .251 - Ø 1 +.010/-0.005	NAME	DATE	Anthony Barber Associates, Ltd 8041 Arrowridge Boulevard, Unit G Charlotte, NC 28273
			DRAWN	Simon Walker	
			CHECKED		TITLE: One Gallon Pump
			ENG APPR.		
			MFG APPR.		SIZE DWG. NO. REV B ABA-80-GCV-RevC
			Q.A.		
			INTERPRET GEOMETRIC TOLERANCING PER: ASME Y14.5 THIRD ANGLE PROJECTION IN PART FABRICATION, BREAK EDGES & DEBURR HOLES .01 TO .02		
			DO NOT SCALE DRAWING		SCALE: 1: 10 WEIGHT: SHEET 1 OF 8
NEXT ASSY	USED ON	MATERIAL			
		FINISH			
APPLICATION					

PROPRIETARY AND CONFIDENTIAL
 THIS INFORMATION CONTAINED IN THIS DRAWING IS THE SOLE PROPERTY OF ANTHONY BARBER ASSOCIATES, LTD (ABA). ANY REPRODUCTION IN PART OR AS A WHOLE WITHOUT THE WRITTEN PERMISSION OF ABA IS STRICTLY PROHIBITED.

4

3

2

1

PARTS LIST			
ITEM	QTY	PART NUMBER	DESCRIPTION
00704	1	ABA-85-26	End Plate
00719	4	ABA-85-38	Tie Rod
00672	1	ABA-85-01	Pump Head Shaft End
00689	1	ABA-85-13	Cylinder Body
00698	2	ABA-85-20	Seal End Pump Cylinder
00678	4	ABA-85-05	3" I-Line Seal
00677	2	ABA-85-04	Check Valve Seat
01878	2	ABA-85-04-UHMW	Check Valve Spacer
00688	4	ABA-85-12	3" I-Line Clamp
00713	1	ABA-85-37	1 Gallon Pump Air Motor
TA	1	ABA-85 Turret Assembly	ABA-85 Turret Assembly
00735	1	ABA-85-55	Turret Base Plate
00695	2	ABA-85-17	Coined Cup Support Disc
00511	2	ABA-168-31	Piston Cup
00693	1	ABA-85-15	Pump Piston
00696	1	ABA-85-18	Sealing Ring for Pump Piston Shaft
00709	1	ABA-85-30	Center Bearing Button
00711	1	ABA-85-31 REV1	Tensioner Rod
00706	1	ABA-85-28	Tensioner Plate
00518	6	ABA-168-38	Gland Packing
00703	1	ABA-85-25	Packing Gland Sleeve
00700	1	ABA-85-22	Pump Piston Rod
00738	1	ABA-85-57	Flange Bearing
00746	1	ABA-85-64	Lock Collar
00753	1	ABA-85-71	Valve Actuator Arm.ipt
00754	1	ABA-85-72	Nylon Pin
00755	1	ABA-85-73	Head Pin
00752	1	ABA-85-70	Valve Actuator Mounting Block
00760	1	ABA-85-78	Friction Button
00749	1	ABA-85-67	Index Pin
00747	1	ABA-85-65	Pin Holder Mounting Angle
00725	1	ABA-85-44	Striker Angle
00724	1	ABA-85-43	Striker Angle Standoff Spacer
00727	1	ABA-85-45	Coupling Retainer Plate
00712	1	ABA-85-32	Coupling Nut
00721	1	ABA-85-41	Coupling Block
00705	2	ABA-85-27	Tie Rod Shaft
00697	1	ABA-85-19	Jam Nut Extra Large
00699	4	ABA-85-21	SS Hex Thin Nut
00510	1	ABA-168-302	Wear Ring
00674	1	ABA-85-02	Pump Head Blind End
00748	1	ABA-85-66	Index Pin Holder
00750	1	ABA-85-68	Index Pin Knob
A	00736	ABA-85-56SS	Turret Mounting Shaft
00496	1	ABA-168-16	Teflon Sleeve
03094	2	ABA-85-39	SS SHCS 3/8"-24 Thread, 1-1/4" Length
00732	1	ABA-85-51	Brass Pipe Nipple, 3/5 Pipe x 2"
03309	1	ABA-85-64B	SS Socket Set Screw 1/4"-20 x 1/4"
00751	1	ABA-85-69	SS Socket Set Screw 10-24 x 1/4"
00722	1	ABA-85-42	Pneumatic Power Valve
00756	1	ABA-85-74	Compression Spring .297" ID x 1.28"
00744	1	ABA-85-62	1" Compression Spring
00757	1	ABA-85-75	Spring Pin 3/16" x 1"
00723	2	ABA-85-42B	Muffler 3-8 NPT x 1.5
02081	3	KQ2L11-36S	Elbow 3/8" Tube x 3/8" NPT Male

ABA-80-BODY - One Gallon Pump Body

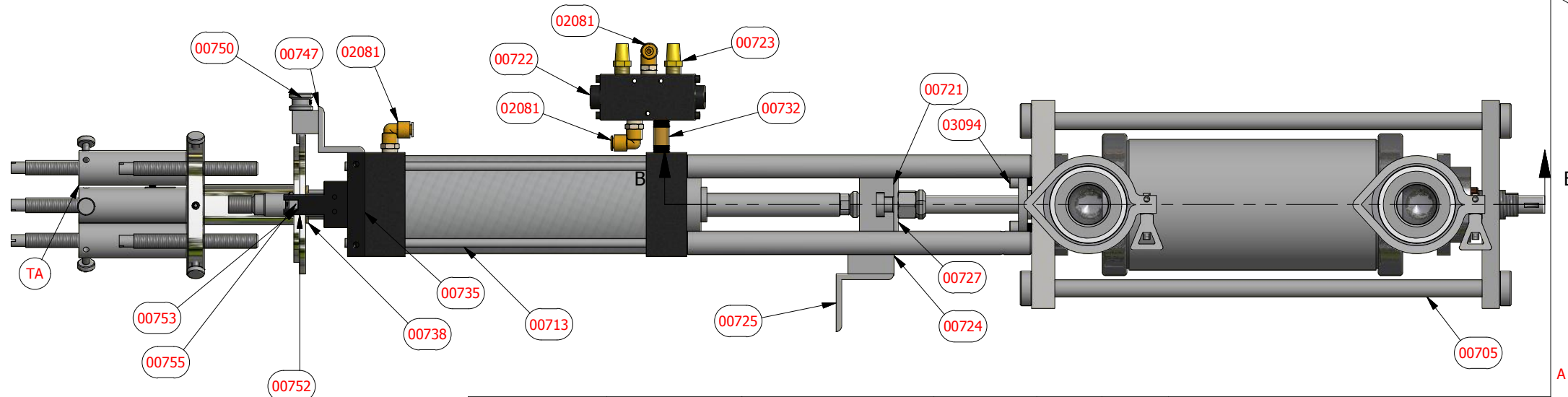
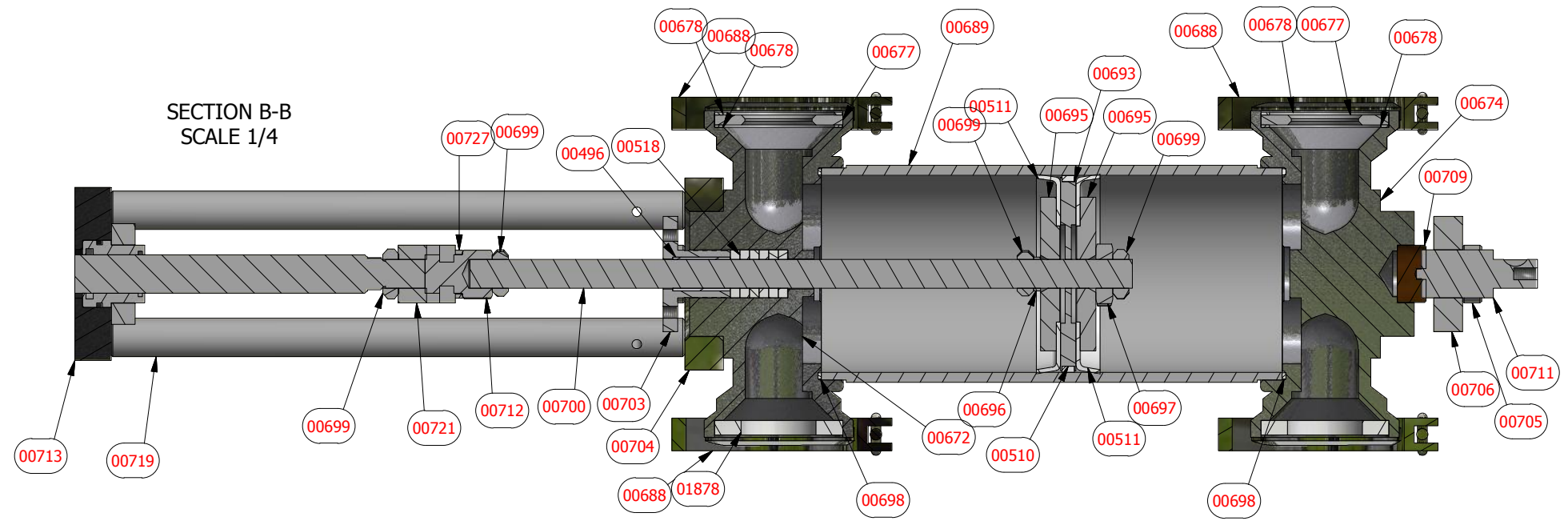

PROPRIETARY AND CONFIDENTIAL
 THIS INFORMATION CONTAINED IN THIS DRAWING IS THE SOLE PROPERTY OF ANTHONY BARBER ASSOCIATES, LTD (ABA). ANY REPRODUCTION IN PART OR AS A WHOLE WITHOUT THE WRITTEN PERMISSION OF ABA IS STRICTLY PROHIBITED.

UNLESS OTHERWISE SPECIFIED DIMENSIONS ARE IN INCHES		NAME		DATE		Anthony Barber Associates, Ltd 8041 Arrowridge Boulevard, Unit G Charlotte, NC 28273	
TOLERANCES:		DRAWN		Simon Walker		5/12/2014	
ANGULAR MACH ±0.5° BEND ±1°		CHECKED				TITLE:	
THREE PLACE DECIMAL ±.005"		ENG APPR.				One Gallon Pump	
TWO PLACE DECIMAL ±.01"		MFG APPR.				SIZE DWG. NO.	
ONE PLACE DECIMAL ±.1"		Q.A.				B ABA-80-GCV-RevC	
INTEGER (NO DECIMAL) ±.1"		INTERPRET GEOMETRIC TOLERANCING PER: ASME Y14.5				REV	
FRACTIONAL ± 1/32"		THIRD ANGLE PROJECTION				SCALE: 1: 10	
HOLES: Ø 0 - Ø .125 +.004/- .002		IN PART FABRICATION, BREAK EDGES & DEBURR HOLES .01 TO .02				WEIGHT:	
Ø .126 - Ø .25 +.006/- .003		DO NOT SCALE DRAWING				SHEET 2 OF 8	
Ø .251 - Ø 1 +.010/- .005		APPLICATION					
NEXT ASSY		USED ON					

ABA-80-GCV - One Gallon Pump Body

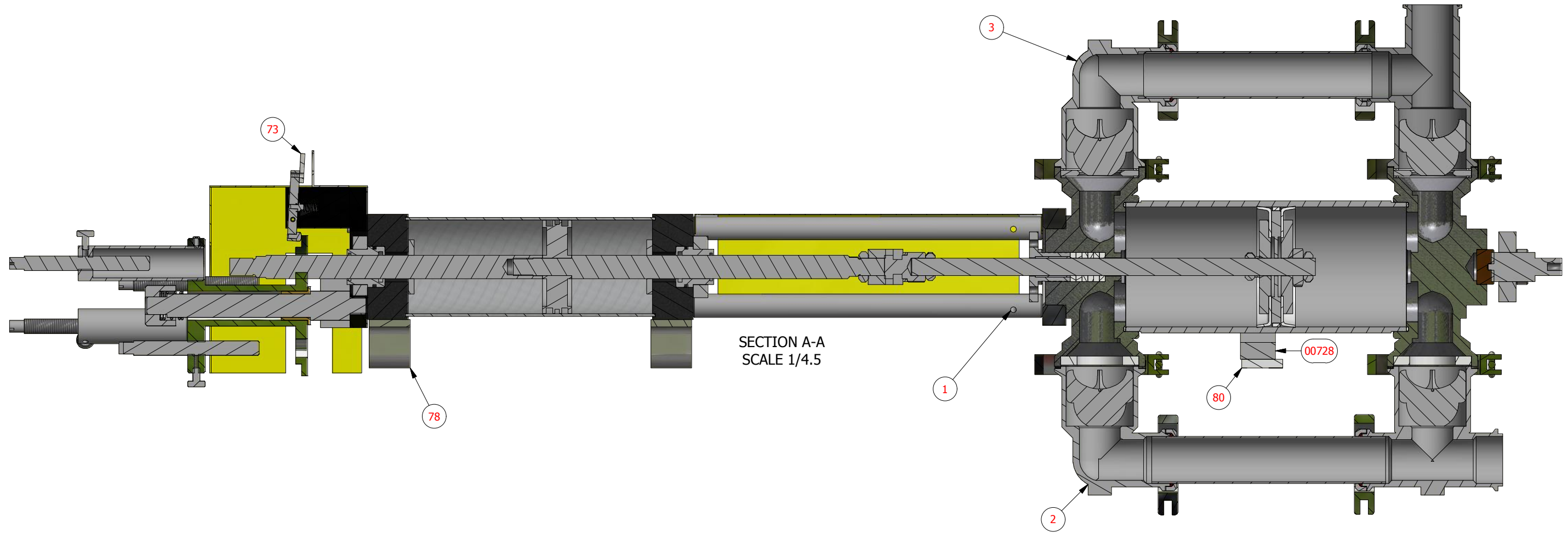
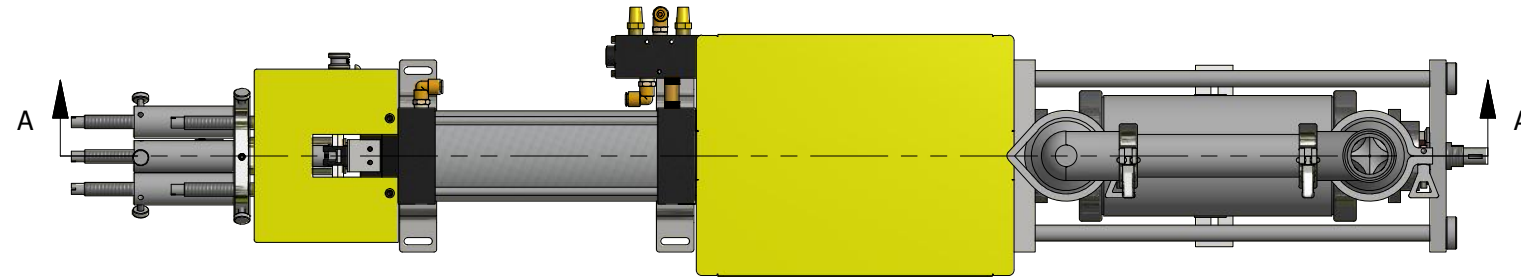

PARTS LIST			
ITEM	QTY	PART NUMBER	DESCRIPTION
1	1	ABA-PUMP-1-BODY	One Gallon Pump Body
2	1	ABA-80-GCV-MAN-B	One Gallon Pump Bottom Manifold with Gravity Check Valves
3	1	ABA-80-GCV-MAN-T	One Gallon Pump Top Manifold with Gravity Check Valves
00728	1	ABA-85-47	1 Gallon Pump Saddle
73	1	ABA-425-42G RevA	Flag, Sensor Prox Pump Turret
74	1	ABA-425-42F RevB	Bracket, Prox Pump, 18mm
78	2	ABA-BRKT-0148	Pump Bracket
80	1	ABA-BRKT-013 RevB	1 Gallon Pump Mounting Bracket
82	1	ABA-85-77-RevB	One Gallon Pump Turret Guard
83	1	ABA-85-50	Pump Guard

PROPRIETARY AND CONFIDENTIAL
 THIS INFORMATION CONTAINED IN THIS DRAWING IS THE SOLE PROPERTY OF ANTHONY BARBER ASSOCIATES, LTD (ABA). ANY REPRODUCTION IN PART OR AS A WHOLE WITHOUT THE WRITTEN PERMISSION OF ABA IS STRICTLY PROHIBITED.

		UNLESS OTHERWISE SPECIFIED DIMENSIONS ARE IN INCHES		DRAWN: Simon Walker		DATE: 5/12/2014		Anthony Barber Associates, Ltd 8041 Arrowridge Boulevard, Unit G Charlotte, NC 28273			
		TOLERANCES: ANGULAR: MACH ±0.5° BEND ±1° THREE PLACE DECIMAL ±.005" TWO PLACE DECIMAL ±.01" ONE PLACE DECIMAL ±.1" INTEGER (NO DECIMAL) ±.1" FRACTIONAL ± 1/32" HOLES: Ø 0 - .125 +.004/-0.002 Ø .126 - .25 +.006/-0.003 Ø .251 - Ø 1 +.010/-0.005		CHECKED:		ENG APPR:		MFG APPR:		TITLE: One Gallon Pump	
		MATERIAL:		Q.A.		INTERPRET GEOMETRIC TOLERANCING PER: ASME Y14.5		SIZE DWG. NO. REV			
NEXT ASSY		USED ON		THIRD ANGLE PROJECTION		IN PART FABRICATION, BREAK EDGES & DEBURR HOLES .01 TO .02		SCALE: 1:10 WEIGHT: SHEET 3 OF 8			
APPLICATION				DO NOT SCALE DRAWING		ABA-80-GCV-RevC					

ABA-80-BODY - One Gallon Pump Body Exploded

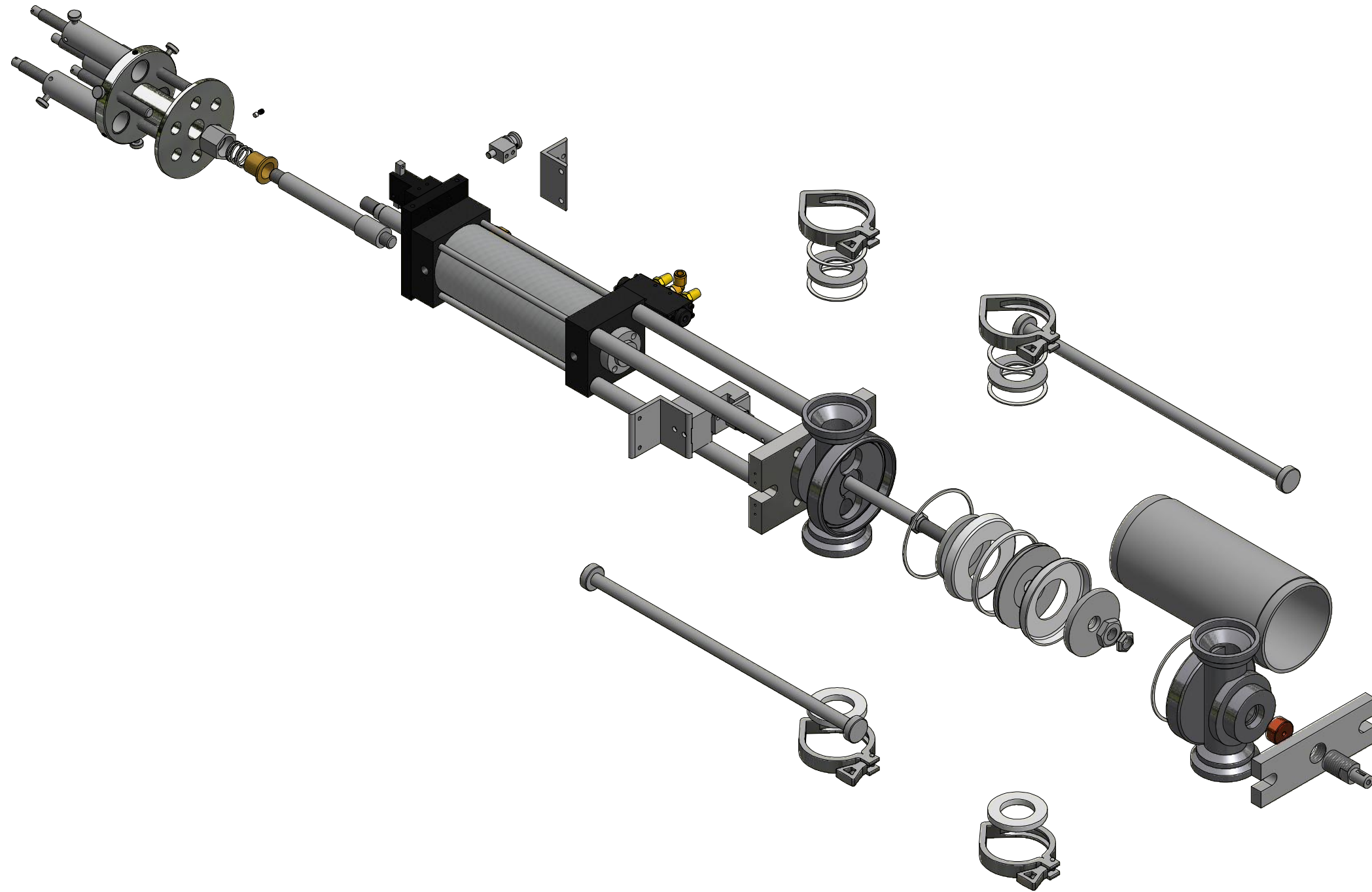

PROPRIETARY AND CONFIDENTIAL
 THIS INFORMATION CONTAINED IN THIS
 DRAWING IS THE SOLE PROPERTY OF
 ANTHONY BARBER ASSOCIATES, LTD (ABA).
 ANY REPRODUCTION IN PART OR AS A
 WHOLE WITHOUT THE WRITTEN PERMISSION
 OF ABA IS STRICTLY PROHIBITED.

		UNLESS OTHERWISE SPECIFIED DIMENSIONS ARE IN INCHES TOLERANCES: ANGULAR: MACH ±0.5° BEND ±1" THREE PLACE DECIMAL ±.005" TWO PLACE DECIMAL ±.01" ONE PLACE DECIMAL ±.1" INTEGER (NO DECIMAL) ±.1" FRACTIONAL ± 1/32" HOLES: Ø 0 - Ø .125 +.004/-.002 Ø .126 - Ø .25 +.006/-.003 Ø .251 - Ø 1 +.010/-.005	DRAWN	NAME	DATE	Anthony Barber Associates, Ltd 8041 Arrowridge Boulevard, Unit G Charlotte, NC 28273	
			CHECKED	Simon Walker	5/12/2014		TITLE: One Gallon Pump
			ENG APPR.				
			MFG APPR.				
			Q.A. INTERPRET GEOMETRIC TOLERANCING PER: ASME Y14.5			SIZE DWG. NO. B ABA-80-GCV-RevC	
			THIRD ANGLE PROJECTION IN PART FABRICATION, BREAK EDGES & DEBURR HOLES .01 TO .02			REV	
			DO NOT SCALE DRAWING			SCALE: 1:10 WEIGHT: SHEET 4 OF 8	
NEXT ASSY	USED ON	MATERIAL					
APPLICATION		FINISH					

ABA-80-GCV-MAN-T - One Gallon Pump Top Manifold

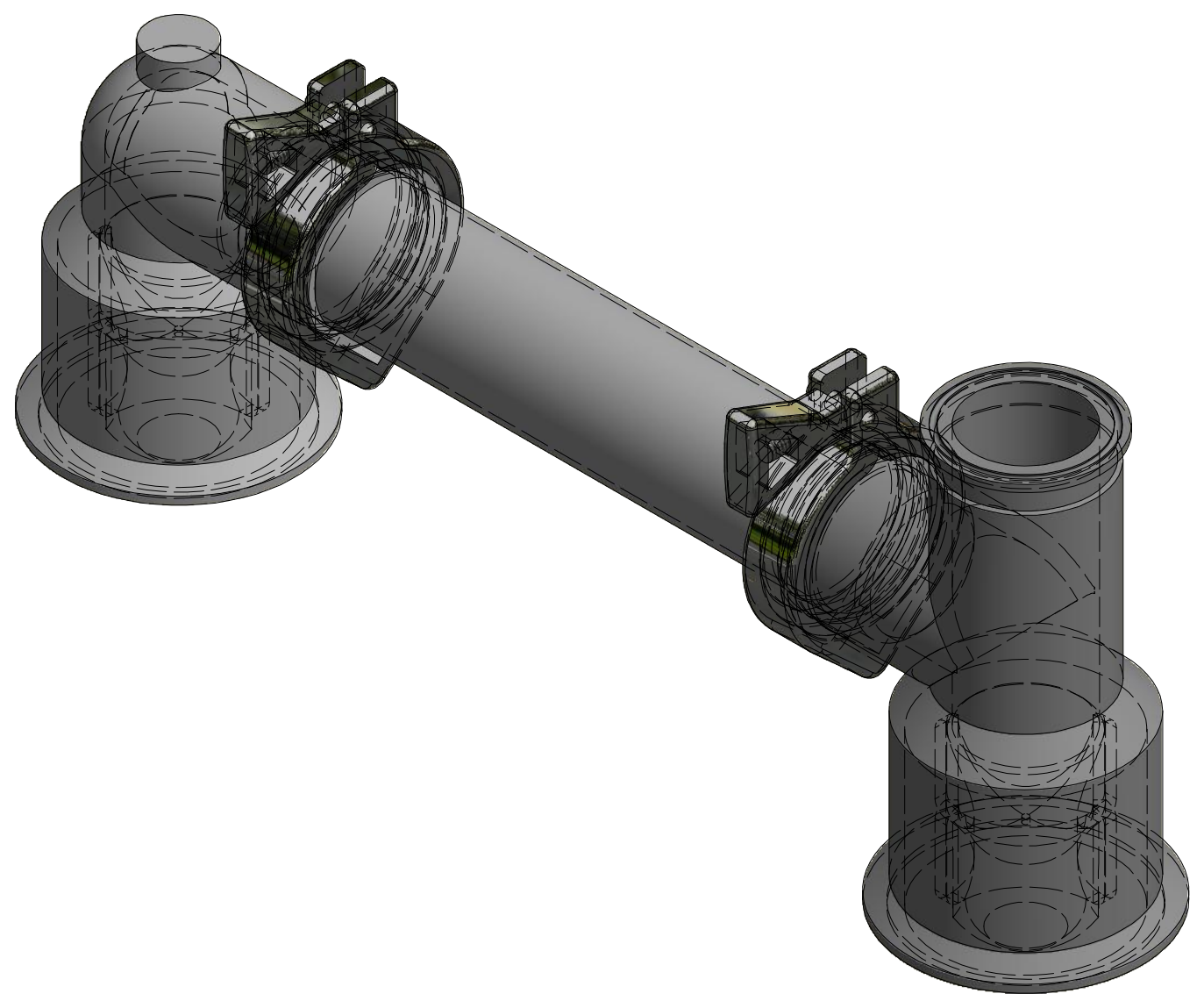
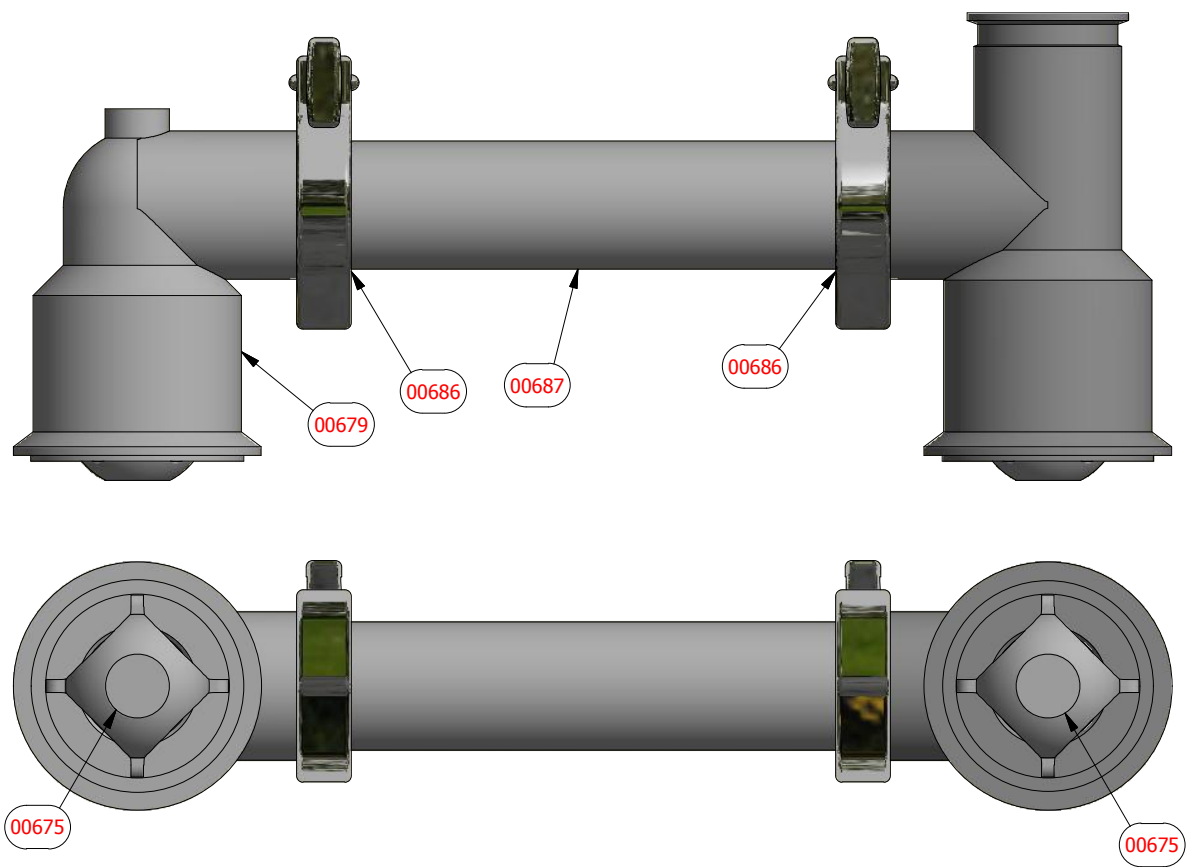

PARTS LIST			
ITEM	QTY	PART NUMBER	DESCRIPTION
00675	2	ABA-85-03	1 Gallon Check Valve
00679	1	ABA-85-06	Elbow Fitting
00687	1	ABA-85-11	10" x 2" Manifold Tube
00686	2	ABA-85-10	2" I-Line Clamp
00683	2	ABA-85-08	2" Clamp Ferrule
00684	2	ABA-85-09	2" Teflon O-Ring
67	1	ABA-85-29	Tee Fitting

PROPRIETARY AND CONFIDENTIAL
 THIS INFORMATION CONTAINED IN THIS DRAWING IS THE SOLE PROPERTY OF ANTHONY BARBER ASSOCIATES, LTD (ABA). ANY REPRODUCTION IN PART OR AS A WHOLE WITHOUT THE WRITTEN PERMISSION OF ABA IS STRICTLY PROHIBITED.

		UNLESS OTHERWISE SPECIFIED DIMENSIONS ARE IN INCHES TOLERANCES: ANGULAR MACH ±0.5° BEND ±1" THREE PLACE DECIMAL ±.005" TWO PLACE DECIMAL ±.01" ONE PLACE DECIMAL ±.1" INTEGER (NO DECIMAL) ±.1" FRACTIONAL ± 1/32" HOLES: Ø 0 - Ø .125 +.004/-.002 Ø .126 - Ø .25 +.006/-.003 Ø .251 - Ø 1 +.010/-.005	DRAWN NAME DATE Simon Walker 5/12/2014	CHECKED ENG APPR. MFG APPR. Q.A.	INTERPRET GEOMETRIC TOLERANCING PER: ASME Y14.5 THIRD ANGLE PROJECTION IN PART FABRICATION, BREAK EDGES & DEBURR HOLES: .01 TO .02 DO NOT SCALE DRAWING	Anthony Barber Associates, Ltd 8041 Arrowridge Boulevard, Unit G Charlotte, NC 28273 TITLE: <h2 style="color: red; margin: 0;">One Gallon Pump</h2>	SIZE DWG. NO. REV B ABA-80-GCV-RevC	SCALE: 1: 10 WEIGHT: SHEET 5 OF 8
NEXT ASSY USED ON APPLICATION	MATERIAL FINISH							

ABA-80-GCV-MAN-B - One Gallon Pump Bottom Manifold

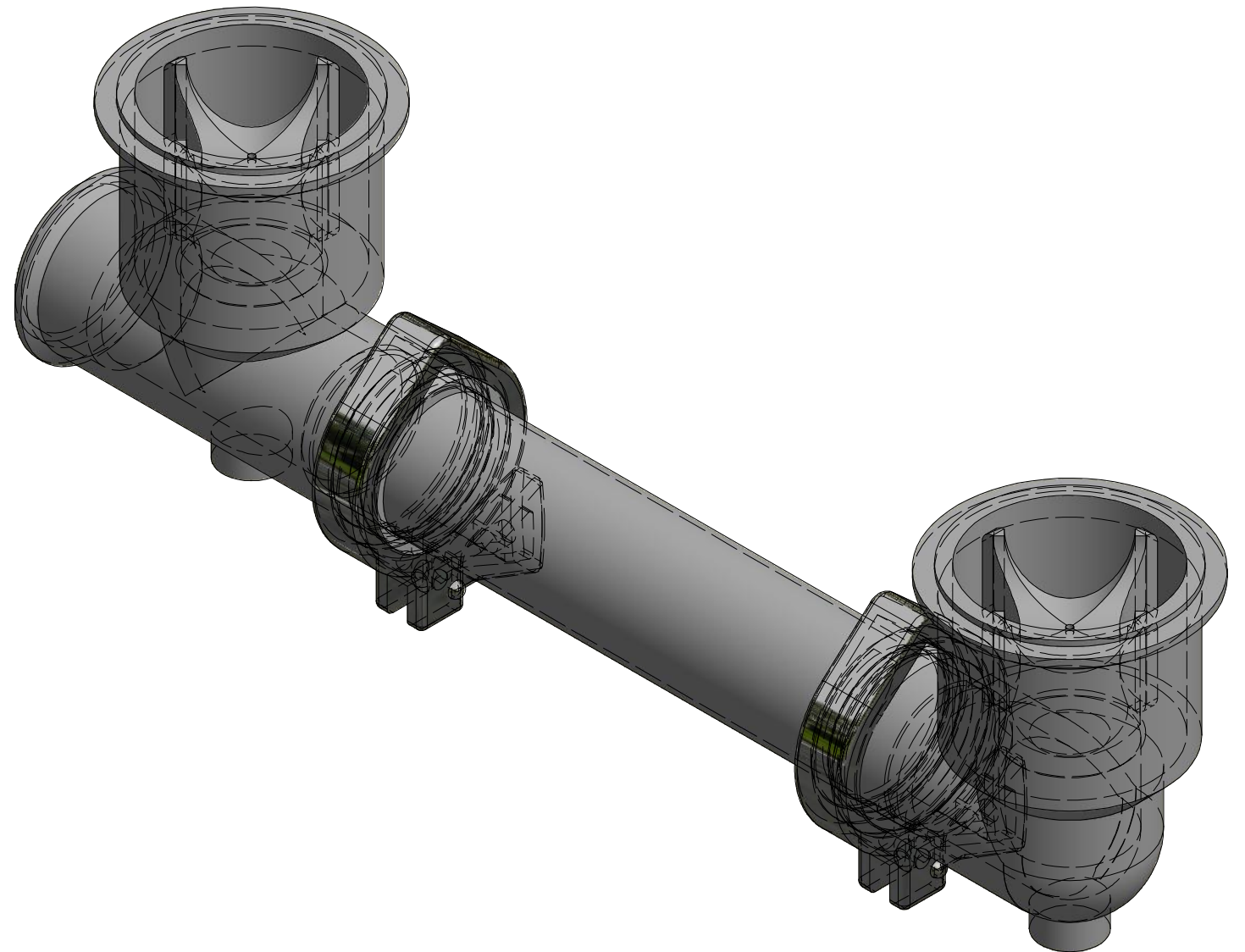
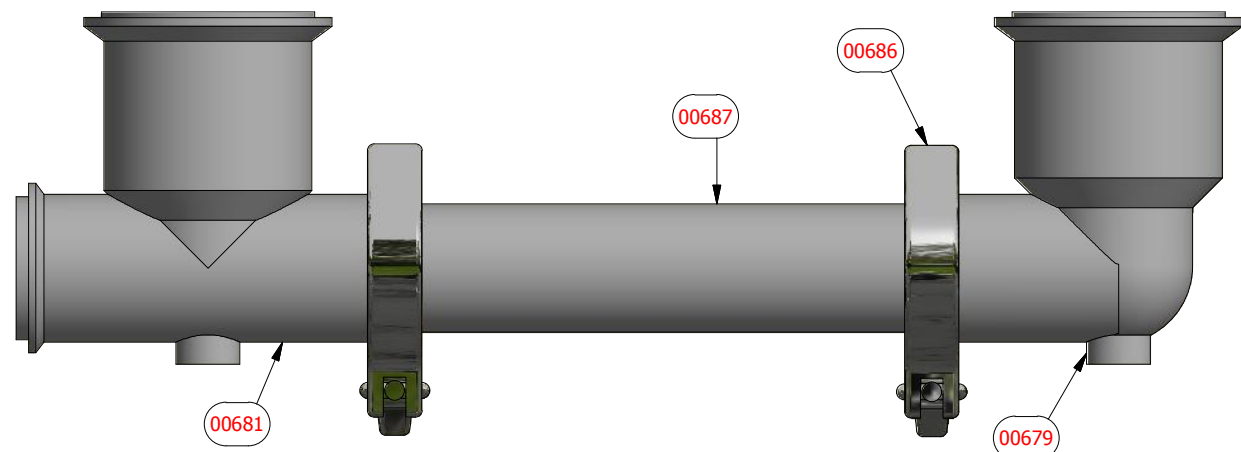
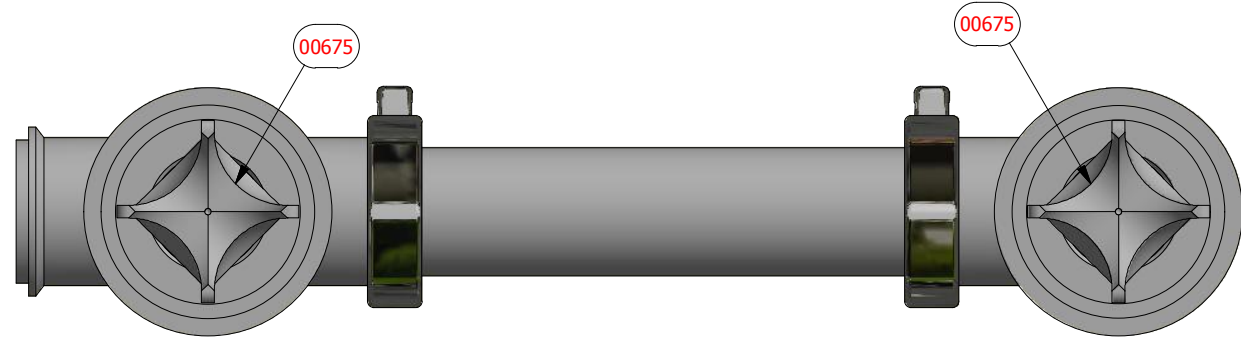

PARTS LIST			
ITEM	QTY	PART NUMBER	DESCRIPTION
00675	2	ABA-85-03	1 Gallon Check Valve
00681	1	ABA-85-07	Tee Fitting
00679	1	ABA-85-06	Elbow Fitting
00687	1	ABA-85-11	10" x 2" Manifold Tube
00686	2	ABA-85-10	2" I-Line Clamp
00683	2	ABA-85-08	2" Clamp Ferrule
00684	2	ABA-85-09	2" Teflon O-Ring

PROPRIETARY AND CONFIDENTIAL
THIS INFORMATION CONTAINED IN THIS DRAWING IS THE SOLE PROPERTY OF ANTHONY BARBER ASSOCIATES, LTD (ABA). ANY REPRODUCTION IN PART OR AS A WHOLE WITHOUT THE WRITTEN PERMISSION OF ABA IS STRICTLY PROHIBITED.

		UNLESS OTHERWISE SPECIFIED DIMENSIONS ARE IN INCHES TOLERANCES: ANGULAR: MACH ±0.5° BEND ±1" THREE PLACE DECIMAL ±.005" TWO PLACE DECIMAL ±.01" ONE PLACE DECIMAL ±.3" INTEGER (NO DECIMAL) ±.1" FRACTIONAL ± 1/32" HOLES: Ø 0 - Ø .125 +.004/-0.002 Ø .126 - Ø .25 +.006/-0.003 Ø .251 - Ø 1 +.010/-0.005	DRAWN Simon Walker 5/12/2014	NAME DATE	 Anthony Barber Associates, Ltd 8041 Arrowridge Boulevard, Unit G Charlotte, NC 28273
			CHECKED		TITLE: One Gallon Pump
			ENG APPR.		
			MFG APPR.		
			Q.A.		
		MATERIAL	INTERPRET GEOMETRIC TOLERANCING PER: ASME Y14.5		
		FINISH	THIRD ANGLE PROJECTION IN PART FABRICATION, BREAK EDGES & DEBURR HOLES .01 TO .02		SIZE DWG. NO. B ABA-80-GCV-RevC
NEXT ASSY	USED ON	DO NOT SCALE DRAWING		SCALE: 1: 10	WEIGHT:
APPLICATION				SHEET 6 OF 8	

ABA-80 - One Gallon Pump Turrett

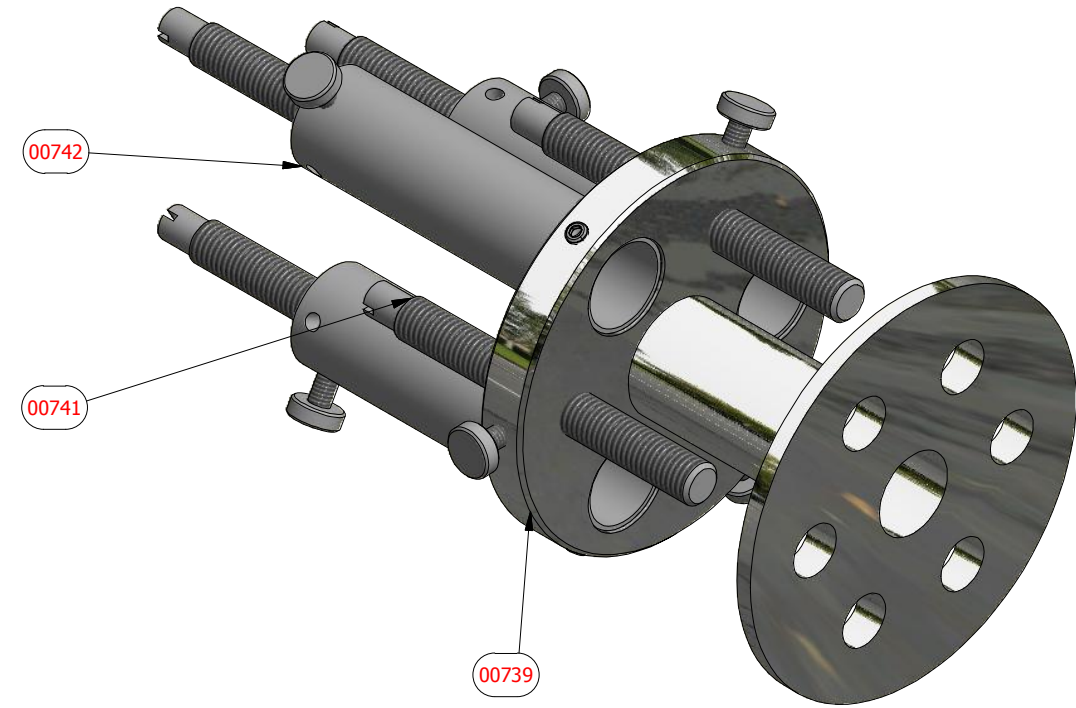
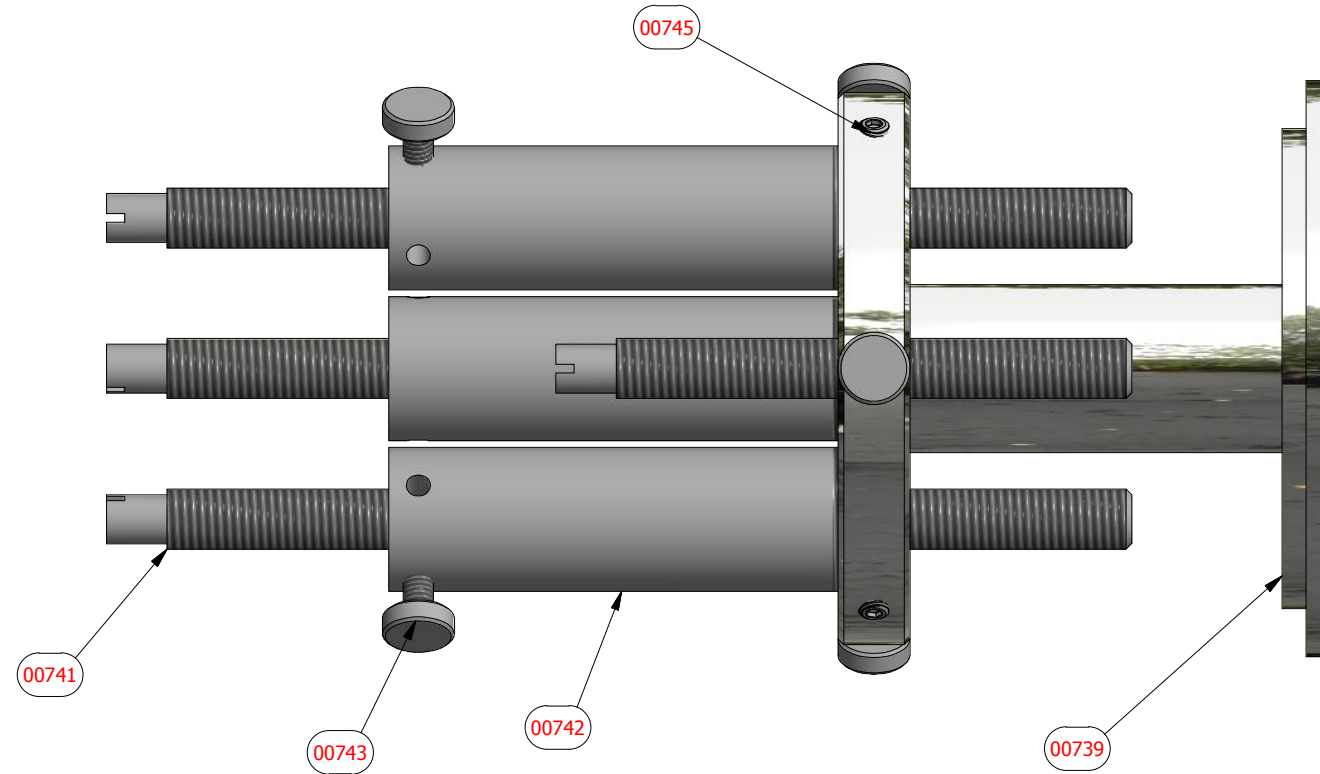

PARTS LIST			
ITEM	QTY	PART NUMBER	DESCRIPTION
00739	1	ABA-85-58SS	Turret Body
00741	6	ABA-85-59	Turret Shot Selector
00742	3	ABA-85-60	Turret Shot Selector Extension
00743	6	ABA-85-61	Thumb Screw
00745	3	ABA-85-63	SS Socket Set Screw 5/16"-18 x 3/8"

PROPRIETARY AND CONFIDENTIAL
 THIS INFORMATION CONTAINED IN THIS DRAWING IS THE SOLE PROPERTY OF ANTHONY BARBER ASSOCIATES, LTD (ABA). ANY REPRODUCTION IN PART OR AS A WHOLE WITHOUT THE WRITTEN PERMISSION OF ABA IS STRICTLY PROHIBITED.

		UNLESS OTHERWISE SPECIFIED DIMENSIONS ARE IN INCHES		DRAWN Simon Walker 5/12/2014		Anthony Barber Associates, Ltd 8041 Arrowridge Boulevard, Unit G Charlotte, NC 28273			
		TOLERANCES: ANGULAR: MACH ±0.5° BEND ±1" THREE PLACE DECIMAL ±.005" TWO PLACE DECIMAL ±.01" ONE PLACE DECIMAL ±.1" INTEGER (NO DECIMAL) ±1" FRACTIONAL ± 1/32" HOLES: Ø 0 - Ø .125 +.004/-0.002 Ø .126 - Ø .25 +.006/-0.003 Ø .251 - Ø 1 +.010/-0.005		CHECKED		TITLE: One Gallon Pump			
		MATERIAL		ENG APPR.		SIZE DWG. NO. REV			
NEXT ASSY		USED ON		MFG APPR.		B ABA-80-GCV-RevC			
APPLICATION				Q.A.		SCALE: 1:10 WEIGHT: SHEET 7 OF 8			
				INTERPRET GEOMETRIC TOLERANCING PER: ASME Y14.5					
				THIRD ANGLE PROJECTION IN PART FABRICATION, BREAK EDGES & DEBURR HOLES .01 TO .02					
				DO NOT SCALE DRAWING					

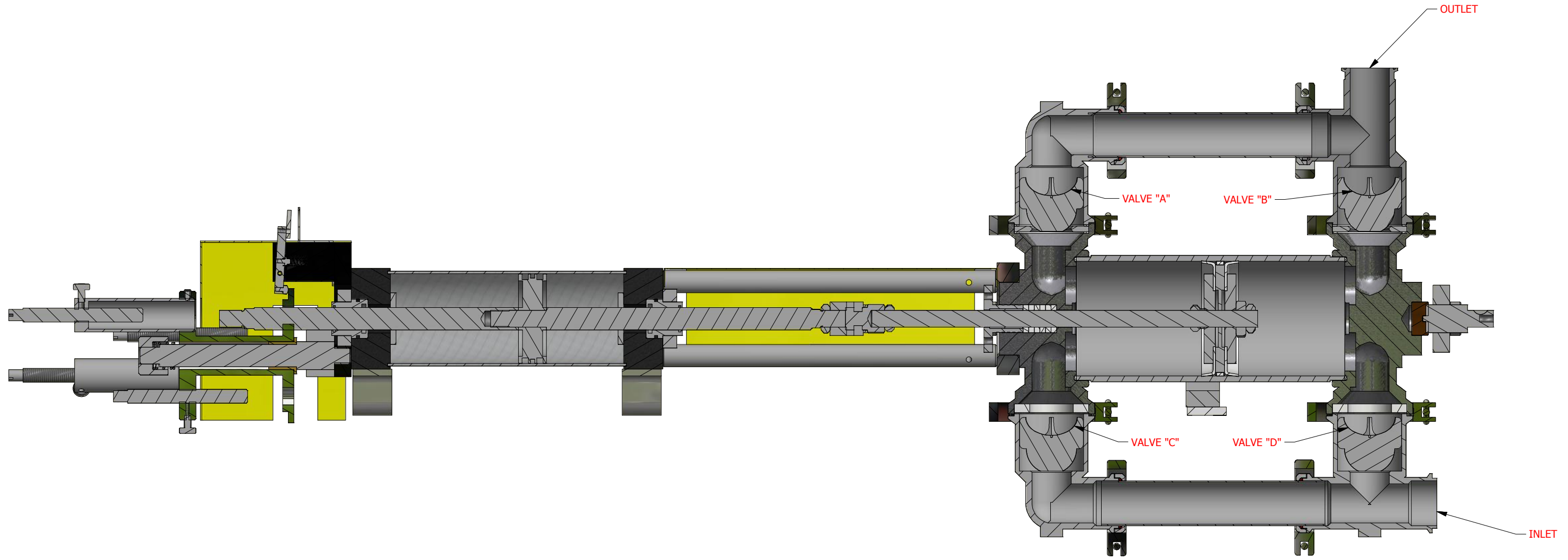

PROPRIETARY AND CONFIDENTIAL
 THIS INFORMATION CONTAINED IN THIS DRAWING IS THE SOLE PROPERTY OF ANTHONY BARBER ASSOCIATES, LTD (ABA). ANY REPRODUCTION IN PART OR AS A WHOLE WITHOUT THE WRITTEN PERMISSION OF ABA IS STRICTLY PROHIBITED.

		UNLESS OTHERWISE SPECIFIED DIMENSIONS ARE IN INCHES TOLERANCES: ANGULAR: MACH ±0.5° BEND ±1° THREE PLACE DECIMAL ±.005" TWO PLACE DECIMAL ±.01" ONE PLACE DECIMAL ±.1" INTEGER (NO DECIMAL) ±.1" FRACTIONAL ± 1/32" HOLES: Ø 0 - Ø .125 +.004/-0.002 Ø .126 - Ø .25 +.006/-0.003 Ø .251 - Ø 1 +.010/-0.005	NAME	DATE	 Anthony Barber Associates, Ltd 8041 Arrowridge Boulevard, Unit G Charlotte, NC 28273
			DRAWN	Simon Walker	
		MATERIAL	CHECKED		TITLE: One Gallon Pump
		FINISH	ENG APPR.		
			MFG APPR.		Q.A. INTERPRET GEOMETRIC TOLERANCING PER: ASME Y14.5 THIRD ANGLE PROJECTION IN PART FABRICATION, BREAK EDGES & DEBURR HOLES .01 TO .02 DO NOT SCALE DRAWING
					SIZE DWG. NO. REV B ABA-80-GCV-RevC
					SCALE: 1:10 WEIGHT: SHEET 8 OF 8

NEXT ASSY	USED ON	
APPLICATION		



Anthony Barber Associates Ltd., USA

8041 Arrowridge Boulevard, Suite G, Charlotte, NC 28273

Tel: +1 (704) 714-3494

Fax: +1 (704) 714-3496











<http://www.abaltd.com>

sales@abaltd.com











Bill Of Materials

Product:	ABA-80 with pneumatic poppet valves One gallon volumetric pump complete with air motor and 6 position turret, gravity check valves
Product Qty:	1
Customer:	
Job Number:	



Part ID	Part Number	Qty	Description	Photo
00672 (01)	ABA-85-01	1	One Gallon Pump Head, Shaft End (Include 2 x 92196A583 5/8-18 x 1 screws screws if send out as a spare part)	
00674 (02)	ABA-85-02	1	One Gallon Pump Head, Blind End	
00675 (03)	ABA-85-03	4	Check Valve (4 per)	
01878 (04)	ABA-85-04-UHMW	2	UHMW 1 Gallon Pump Check Valve Spacer	
00677 (04)	ABA-85-04	2	Check Valve Seat Stainless Steel (4 Per)	
00678 (05)	ABA-85-05	4	3inch I-Line Seal/Gasket 3.33 inch OD (Optional replacement ABA-85-05-FEP)	
00679 (06)	ABA-85-06	2	1 Gallon Pump Elbow fitting (2 per)	
00681 (07)	ABA-85-07	1	1 Gallon Pump Tee Fitting (1 Per)	

				
00683 (08)	ABA-85-08	4	2 inch Clamp ferrule (4 Per Pump) same as ABA-PM80-13	
00684 (09)	ABA-85-09	5	O Ring silicone encap. Tef 2 inch ID, 2.25 OD x 1/8 (ABA-COV-SML-02)	
00686 (10)	ABA-85-10	4	2 inch I-Line Clamp CIP	
00687 (11)	ABA-85-11	2	Manifold tube (2 Per Pump)	
00688 (12)	ABA-85-12	4	3 inch I-Line Clamp CIP	
00689 (13)	ABA-85-13	1	Cylinder body, 316 S/S	
00511 (14)	ABA-168-31	2	590-1445 15/45 Piston cup (ABA-85-14)	
00693 (15)	ABA-85-15	1	Pump Piston	
00510 (16)	ABA-168-302	1	Wear ring (ABA-85-16) (Replaces ABA-PM80-26)	
00695 (17)	ABA-85-17	2	Coined cup disk support (2 per pump)	
00696 (18)	ABA-85-18	1	Sealing Ring for Pump Piston Shaft (1 Per Pump)	

				
00697 (19)	ABA-85-19	1	Jam nut extra large (1 PER PUMP)	
00698 (20)	ABA-85-20	2	Cylinder gasket (2 per pump)	
00699 (21)	ABA-85-21	4	Type 316 Stainless Steel Hex Thin (Jam) Nut 3/4-16 Screw Size, 1-1/8 Width, 27/64 Height (4 per pump)	
00700 (22)	ABA-85-22	1	Pump Piston Rod, .75 inch diameter, 3/4-16 thread E/E, 32 finish	
00518 (23)	ABA-168-38	1	Gland packing pump, .75 ID x 1.25OD x .25, set of six rings (ABA-85-23)(60008161A)	
00496 (24)	ABA-168-16	1	Teflon sleeve, gland adj. (ABA-85-24)	
00703 (25)	ABA-85-25	1	Packing Gland Sleeve/Press (1 Per)	
02737 (25B)	92196A585	2	18-8 Stainless Steel Socket Head Cap Screw 5/16-18 Thread, 1-1/4 Length	
02847 (25c)	91102A030	2	18-8 Stainless Steel Split Lock Washer 5/16 Screw Size, .59 OD, .07 min Thick	
02846 (25d)	90126A030	2	Stainless Steel SAE Flat Washer 5/16 Sz, 11/32 Id, 11/16 Od, .051	
00704	ABA-85-26	1	1 Gallon Pump End Plate (1 Per)	

(26)				
00705 (27)	ABA-85-27	2	Pump Tie Rod Shaft (2 Per)	
00706 (28)	ABA-85-28	1	1 Gallon Pump Tensioner plate	
00707 (29)	ABA-85-29	1	One Gallon Pump, Tee Fitting Outlet (Uses S-Line)	
00709 (30)	ABA-85-30	1	Brass Center Bearing Button	
00711 (31B)	ABA-85-31B	1	Tensioner rod with handwheel assy. 1/2inch bore x 6inch	
00712 (32)	ABA-85-32	1	Coupling nut (1 Per)	
00442 (33)	ABA-08-325	1	Hose adapter, pump inlet T85 and PM80, 2 inch I-line female -1.5 inch NPT Male	
04076 (37)	ABA-PMTR-04X9.125R1	1	Gallon pump air motor cylinder, 4 inch bore x 9.125 inch stroke, SS tie rods and piston rod, replaces ABA-85-37, seal kit P/N is ABA-PMTR-04X9.125R1-SKT needs serial number	
00719 (38)	ABA-85-38	4	1 Gallon Pump Tie Rod 3/8-24 thread(4 per)	
03094 (39)	ABA-85-39	4	18-8 Stainless Steel Socket Head Cap Screw 3/8-24 Thread, 1-1/4 Length (4 per)	

00721 (41)	ABA-85-41	1	1 Gallon Pump Coupling Block	
04769 (42)	L23JJ452O000000	1	L2 Series Valve, 3/8 Ports, Double Air Pilot, 2 Position, 4 Way, w/override, NPTF Ports. Detented use on pneumatically controlled pumps.	
00723 (42B)	ABA-85-42B	2	Exhaust Muffler 3/8 NPT Male, 24 Max SCFM, 1-1/2 Height	
02080 (42C)	169PL-5-32-2	5	Elbow 5/32 Tube x 1/8 NPT Male	
02085 (42D)	68PL-5-32-2	3	Straight Connector 5/32 inch Tube x 1/8 inch NPT Male	
00724 (43)	ABA-85-43	1	Striker Plate Angle Standoff Spacer (1 Per)	
00725 (44)	ABA-85-44	1	Striker Plate Angle	
03420 (44B)	92198A692	2	18-8 SS Hex Head Cap Screw 5/16-18 Thread, 2-1/4 Length	
02846 (44c)	90126A030	2	Stainless Steel SAE Flat Washer 5/16 Sz, 11/32 Id, 11/16 Od,.051	
02847 (44d)	91102A030	2	18-8 Stainless Steel Split Lock Washer 5/16 Screw Size, .59 OD, .07 min Thick	
00726 (44e)	ABA-85-44B	2	18-8 SS Large Dia Flush Head (Elevator) Bolt SQ Neck W/Nut, 1/4-20 Thrd, 1 inch L, Fully Threaded (target for poppet valve)	

00727 (45)	ABA-85-45	1	Coupling retainer plate (1 Per Pump) (requires 2 Hex head cap screw 1/4-20 X 3/4 and 1/4 Lock Washer)	
01125 (45a)	ABA-LINESTOP-05	2	18-8 SS Fully Threaded Hex Head Cap Screw 1/4-20 Thread, 3/4 Length To attach ABA-85-45	
01127 (45b)	ABA-LINESTOP-07	2	18-8 Stainless Steel Spring Lock Washer 1/4 Screw Sz, .260 ID, .487 OD, .062 min Thick To attach ABA-85-45	
02848 (45d)	90126A029	2	18-8 Stainless Steel SAE Flat Washer 1/4 Sz, 9/32 Id, 5/8 Od, .051 Min Thk.	
00728 (47)	ABA-85-47	1	1 Gallon Pump Saddle (1 Per)	
04346 (51)	4568K154	1	Standard-Wall Brass Threaded Pipe Nipple 3/8" Pipe Sz X 2-1/2" L, 13/32" Thrd Length, Sch 40 This is new longer one	
02126 (53)	169PL-8-6	2	Elbow 1/2 inch Tube x 3/8 inch NPT Male	
00735 (55)	ABA-85-55	1	Turret base plate	
00736 (56)	ABA-85-56	1	Turret shaft 3/4-10 thread each end	
00738 (57)	ABA-85-57	2	Flange Bearing 1.002 ID X 1.252 OD X 1 1/4LG (2 Per)	
00739 (58)	ABA-85-58	1	1 Gallon Pump Turret Body 6 Position	

00741 (59B)	ABA-85-59B	6	Turret Shot Selector Pin, 6 inch x 5/8-11 Thread	
00742 (60)	ABA-85-60	3	Turret Shot Selector Pin Extension Tube, 5/8-11 Thread	
00743 (61)	ABA-85-61	3	Spade Head Thumb Screw with Nylon Tip, 5/16-18 Thread, 1 inch Length (Note to picker, if no Nylon tip include one P/N ABA-85-78 Friction button) Replaced with ABA-85-61B Only 3 req, put 3 back in stock	
05582 (61a)	ABA-85-61B	3	18-8 SS Spade Head Thumb Screw with Shoulder 5/16-18 Thread, 1 Length (Note to picker, use one P/N ABA-85-78 Friction button 14-03-05)	
00760 (61B)	ABA-85-78	3	Friction button for thumb screw 85-61 Only 3 req, put 3 back in stock	
00744 (62)	ABA-85-62	1	Turret Shaft Spring 1" x 1.22" OD x .95" wire(1 Per)	
00745 (63)	ABA-85-63	3	18-8 Ss Socket Set Screw W/Nylon Flat Point 5/16-18 Thread, 3/8 Length (3 Per)	
00746 (64)	ABA-85-64	1	Turret Lock Collar	
03309 (64b)	ABA-85-64B	1	Nylon Tip 18-8 SS Socket Set Screw 1/4"-20 Thread, 1/4" Length	
00747 (65)	ABA-85-65	1	Turret Pin Holder Mounting Angle CLR ANDZ (1) 4oz	
00205 (65a)	92240A581	4	18-8 SS Fully Threaded Hex Head Cap Screw 5/16-18 Thread, 3/4 Length	
02846	90126A030	2	Stainless Steel SAE Flat Washer 5/16 Sz, 11/32 Id, 11/16	

(65b)			Od,.051	
02847 (65c)	91102A030	2	18-8 Stainless Steel Split Lock Washer 5/16 Screw Size, .59 OD, .07 min Thick	
00748 (66)	ABA-85-66	1	Turret Index Pin Holder (1 Per)	
02738 (66B)	92949A537	2	18-8 SS Button Head Socket Cap Screw 1/4-20 Thread, 1/2" Length	
00749 (67)	ABA-85-67	1	Turret Index Pin (1 Per) 1oz	
00750 (68)	ABA-85-68	1	Turret Index Pin Knob (1 Per) 2oz	
00751 (69)	ABA-85-69	1	Nylon Tip 18-8 SS Socket Set Screw 10-24 Thread, 1/4" Length	
00752 (70)	ABA-85-70	1	Valve Actuator Mounting Block (1 Per)	
02851 (70B)	92196A251	4	18-8 Stainless Steel Socket Head Cap Screw 10-24 Thread, 1-1/2 Length	
02762 (70C)	92146A011	4	18-8 Stainless Steel Spring Lock Washer #10 Screw Size, .200 in ID, .334 in OD, .047 in min Thk (See also/take from ABA-COV-09 for additional inventory)	
02141 (70d)	92141A011	4	18-8 Stainless Steel Flat Washer 10 Screw Size, 13/64 ID, 7/16 OD, .024-.038 Thk	

00753 (71)	ABA-85-71	1	Valve Actuator Arm 10-24 Thread (1 Per) 2oz	
02717 (71B)	92314A245	1	18-8 Stainless Steel Hex Head Machine Screw 10-24 Thread, 3/4 Length	
02840 (71C)	91841A011	1	18-8 Stainless Steel Machine Screw Nut 10-24 Screw Size, 3/8" Width, 1/8" Height	
00754 (72)	ABA-85-72	1	Pin Nylon - striker button (1 per)	
00755 (73)	ABA-85-73	1	Head Pin Spring Retainer (1 Per)	
00756 (74)	ABA-85-74	2	Valve Actuator Arm Return Spring 1.28inch Long (Also ABA-PM80T-24)	
00757 (75)	ABA-85-75	1	Plain Steel Slotted Spring Pin 3/16" Diameter, 1" Length (1 Per)	
00566 (76)	ABA-425-42C	3	Pneumatic Poppet Valve with bracket uses 2 x 92314A242 10-24 Thread, 1/2 Length Hex head screws (if used on P168 pump substitute BSF screws P/N ABA-425-48)	
00759 (77)	ABA-85-77	1	1 Gallon Pump Turret Guard painted OSHA Yellow	
07459 (80)	ABA-BRKT-0148	2	ABA-80 Pump Bracket	
05077 (81)	ABA-BRKT-033	1	Stainless Steel Pump Saddle Mounting Bracket with slots, 3/8 inch thick	

02742 (82)	92210A712	6	18-8 Stainless Steel Flat Head Sckt Cap Screw 1/2-13 Thread, 1 inch Length	
02502 (83)	8 981 021 343	6	10MM, T-bolt fastening kit, M8 thread L=19 total length 25mm	