



Anthony Barber Associates, Ltd.



MANUFACTURER OF QUALITY LIQUID FILLING EQUIPMENT

9030 Northfield Drive, Fort Mill, SC 29707 | (803) 396-0621 | [www.abaltd.com](http://www.abaltd.com)

# Who we are:



Anthony Barber Associates, Ltd., (ABA) manufactures liquid filling machines, lid placing and closing machines, and sells spare parts for liquid filling machines in the paint, coatings, and chemical industries.

*Family owned and operated small business*

ABA custom designs and builds automatic and semi-automatic filling machines for rigid containers and can fill by weight or by volume.

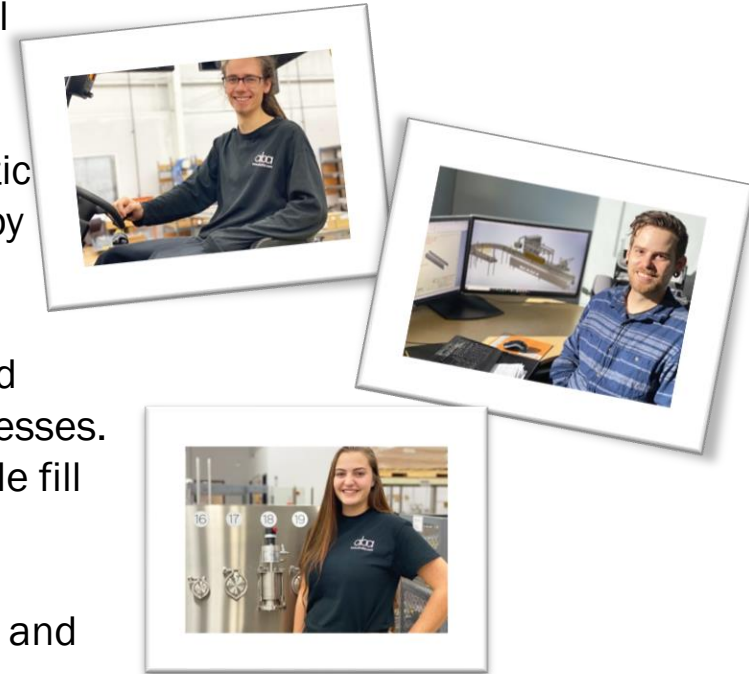

We offer a variety of additional equipment such as rotary feed tables, conveyors, and lid placers, droppers, crimpers and presses. We also supply double action piston pumps and our cone style fill heads.

We design machines for explosion proof areas to meet C1D1 and C1D2 standards



# Net Weight Filling Machines

ABA's net weight filling machines utilize load cells to monitor the weight of the liquid being filled against preset tolerances.

Net weight machines allow for fast and easy clean-up and are highly accurate.

We supply both automatic and semi-automatic filling machines.



# Automatic Net Weight Filling Machines



Anthony Barber Associates, Ltd.



ABA-M582 is a six head, push across (Z-Frame) net weight filling machine featuring dual lid droppers, and a roller lid press.

<https://youtu.be/75T-8m3XUcQ>

ABA-M585 is a 2 head top fill, net weight filling machine with rotary infeed table, lid dropper, and roller lid press.

<https://youtu.be/-3fnAGxUhdA>





ABA-M575 is a 2 head bottom fill filling machine with dual lid crimpers for use in a C1D1 area.

<https://youtu.be/rCiYBFjSljU>

ABA-M523 is a top fill, 2 head, net weight filling machine for a C1D1 area featuring lid placer, lid crimper, fill carts, and a flush cart.

<https://www.youtube.com/watch?v=TZMoEI9rymE>



# Semi-Automatic Net Weight Filling Machines

ABA-M578 is a single head semi-automatic filling machine with crimp station and roller lid press for use in a C1D1 hazardous area.

<https://youtu.be/UkZRz5zazUg>



ABA-M538 is a mobile filling and lid closing machine for use in a C1D1 area featuring a pneumatic lid crimper.

<https://www.youtube.com/watch?v=4Je6WKBw85c&t=79s>



# Volumetric Filling Machines

<http://abaltd.com/products/filling-machines/volumetric.html>

Our volumetric filling machines employ double acting positive displacement volumetric piston pumps to accurately and quickly fill containers.

Double acting pumps have product on both sides of the piston, which prevents drying out and prolongs the life of the parts.

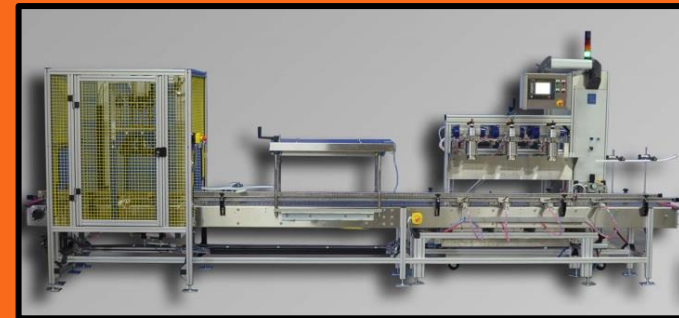
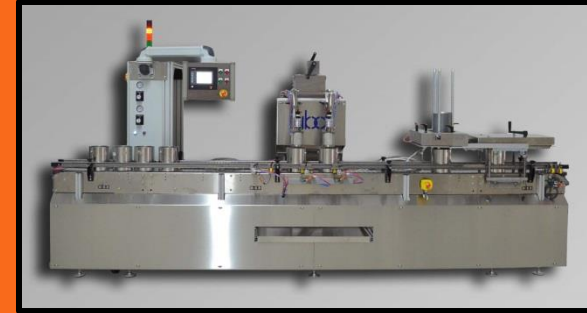

ABA-M548 is a 3 head, top fill, volumetric machine featuring a lid chute, lid dropper with downstacker, and roller lid press.

<https://youtu.be/ExCWP8lolA4>



ABA-M576 is a top fill, dual head machine featuring: rotary infeed table, swing frame fill heads, lid dropper with downstacker, roller lid press, horseshoe conveyor, quart and gallon ring droppers, and ring press.

<https://youtu.be/fHk6dvczuJY>







ABA-M496 is a top fill machine featuring a horseshoe conveyor, lid dropper with downstacker, roller lid press, and one gallon pumps. <https://youtu.be/5urGrNhoz7A>

ABA-M527 is a 4 head, volumetric, push across (Z-frame) filling machine for metal and plastic gallon cans. It features a roller lid press and lid dropper with downstacker as well as two fill carts.

<https://youtu.be/PHSMg6appwc>



ABA-M500 is a 3 head volumetric filling and lidding machine for a C1D1 area. Machine features a roller lid press and lid dropper with downstacker.

[https://youtu.be/kewHKz\\_tgnE](https://youtu.be/kewHKz_tgnE)



# Semi-Automatic Volumetric Filling Machines



Anthony Barber Associates, Ltd.

ABA-M520 is a semi-automatic five gallon filling machine with a wide roller lid press and a 150 gallon product tank

<https://youtu.be/AShtFmmVoSo>



ABA-M541 is a 4 head semi-automatic volumetric filling machine with diving lance fill heads and custom box guides to fill boxed jugs.

<https://youtu.be/1F8m7gLx9AI>



ABA-M571 is a semi-automatic one gallon, bottom fill filling machine for use in a C1D1 area

[https://youtu.be/w\\_oZxtMX3w8](https://youtu.be/w_oZxtMX3w8)



# Drum Filling Machines



Anthony Barber Associates, Ltd.



## ABA-M489

### ABA-TFGES-4-DRUM

ABA-M489 is a net weight, top fill, open drum filling machine with articulating gantry to fill up to 4 drums on a pallet.

<https://www.youtube.com/watch?v=9uIBeF2Fx90>

# Horizontal Denester



ABA-M533 is a plastic pail denester with a pail stack infeed for use with 5 gallon containers. It is designed to run at 20 pails per minute.

[https://youtu.be/ast\\_GpkgYdY](https://youtu.be/ast_GpkgYdY)

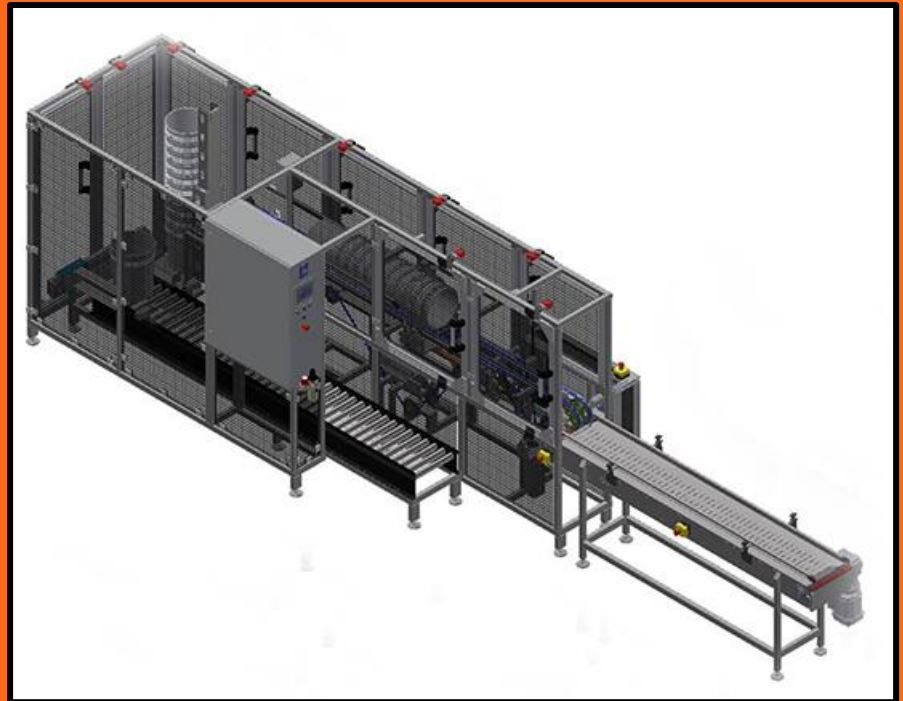

# Lidding

ABA offers a variety of lid placing and closing options to accommodate most container styles and sizes.

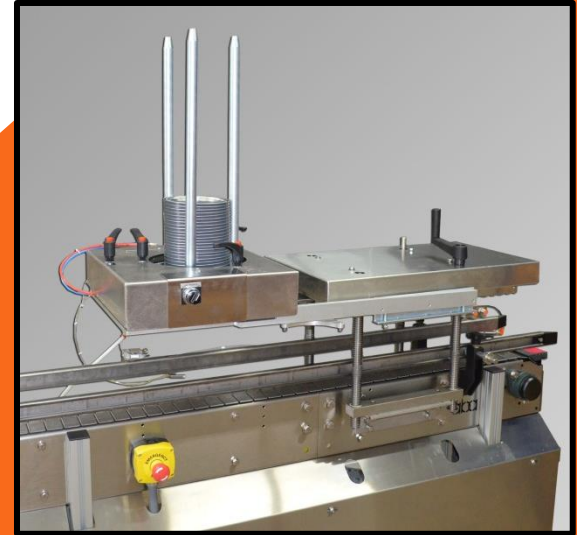

# Lid Placers and Droppers

<http://abaltd.com/products/lidding/lid-placement.html>



Anthony Barber Associates, Ltd.

ABA-M510 is a lid placer for 5 gallon plastic lids with a bung orientation system.

<https://youtu.be/A3vhaY4SIF4>



ABA-M534 is a dual lid placer machine with bung orientation. It is designed to run at 20 placements per minute for standard and UN plastic lids. Designed for a C1D1 hazardous area.

[https://www.youtube.com/watch?v=q\\_bdQDGOR6c](https://www.youtube.com/watch?v=q_bdQDGOR6c)



ABA-LDHS shown below with downstacker for extra capacity.

<https://youtu.be/Cr9RDc80jTw?list=PLUR4QKcv5KlkkjsCtv7eOG4VSKLm9PfYQ>



ABA-LDHS is a high speed lid dropper for metal and plastic lids which mounts to all ABA-lid press units and can drop lids from ½ pint through gallon.

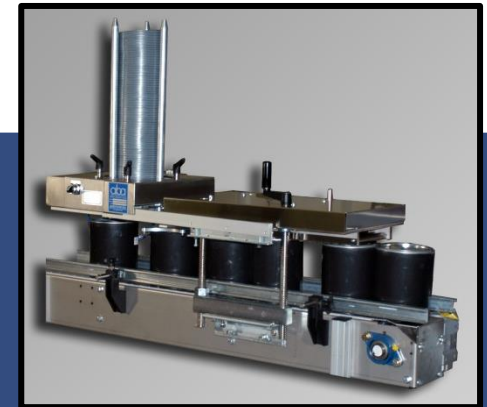



ABA-M516 is a lid dropper with downstacker and roller lid press as well as a paddle reject system designed to eliminate any unlidded cans. <https://youtu.be/nfutSwdYlfg>

ABA-M495 is a conveyor with lid dropper and downstacker, roller lid press, and rotary table.

<https://youtu.be/PZLC5CC9RS0>



ABA-PLCR-CHUTE is a semi-automatic lid placer. The operator pre-loads lids into the chute and can then walk away. This is the perfect middle ground between a fully automatic lid placer and having an operator manually place individual lids by hand.

<https://youtu.be/58iVy70L4Hg?list=PLUR4QKcv5KlkkjsCtv7eOG4VSKLm9PfYQ>



Lid placing/dropping continued

# Lid Closers

<http://www.abaltd.com/products/lidding/lid-closers.html>

## ABA-PRESS-1NAR & -5NAR

ABA's non-powered roller lid presses come in 1 gallon or 5 gallon sizes. These presses are height adjustable and can accommodate from half pint through one gallon containers and 5 gallon pails respectively.

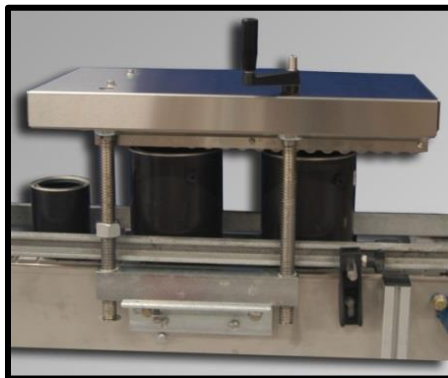

## ABA-PRESS-5GALL-P

Powered press unit designed for closing 5 gallon pails, but can also close 1 gallon pails.

<https://youtu.be/U34tntqli1c?list=PLUR4QKcv5KlkkjsCtv7eOG4VSKLm9PfYQ>

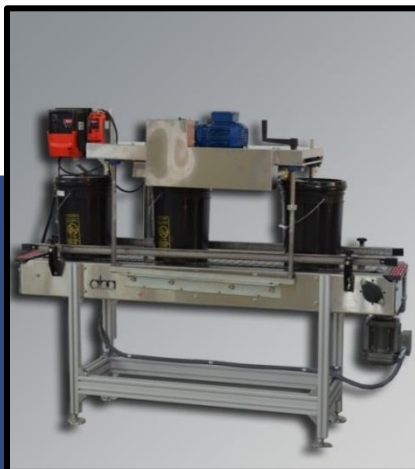

Anthony Barber Associates, Ltd.

## ABA-CRIMP-1PS-FS

This is a mobile lid crimping machine which is designed to close metal lids onto pails which are located on the floor.

<https://www.youtube.com/watch?v=C4DogkrVVpU>

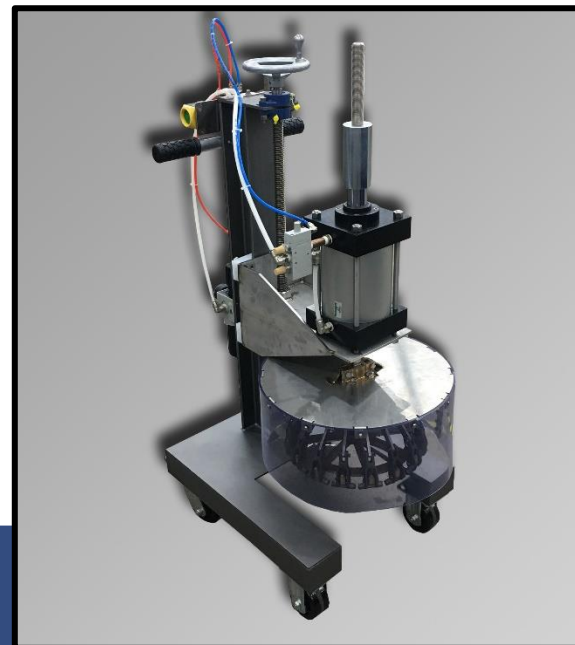



# Volumetric Pumps, Fill Heads, & Accessories

- ABA offers both 1 and 5 gallon volumetric piston pumps, all double acting positive displacement.
- 3 different fill heads available to cover a wide variety of environments and products.
- Accessories increase speed, efficiency, & throughput

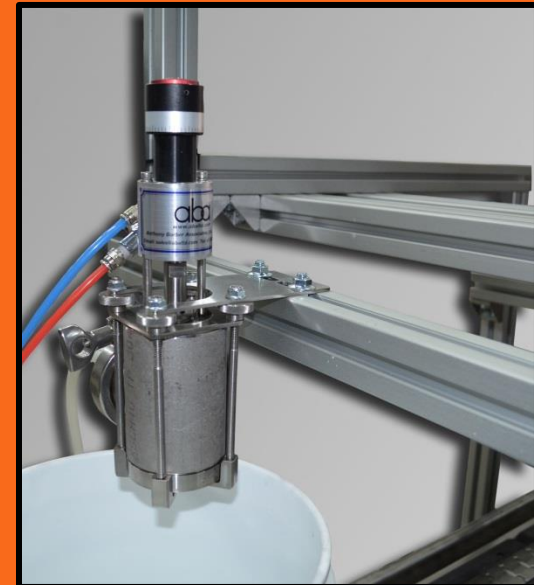
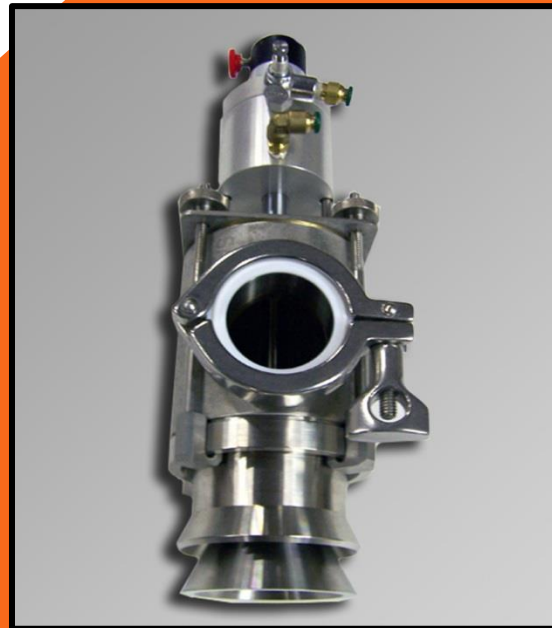
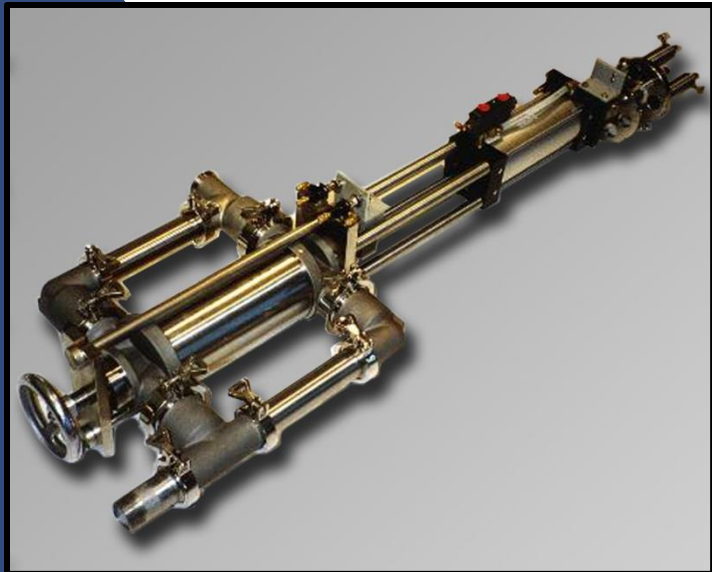

# Volumetric Pumps

<http://www.abaltd.com/products/volumetric-pumps.html>



Anthony Barber Associates, Ltd.

ABA makes and supplies 1 and 5 gallon double acting piston pumps.

Double acting pumps mean there is liquid on both sides of the piston which ensures a longer life for all component parts.

Both size pumps are available with gravity or powered check valves.

The pumps are manufactured from stainless steel and have Teflon seals and gaskets as well as quick release clamps for ease of maintenance.

## 5 Gallon Pumps

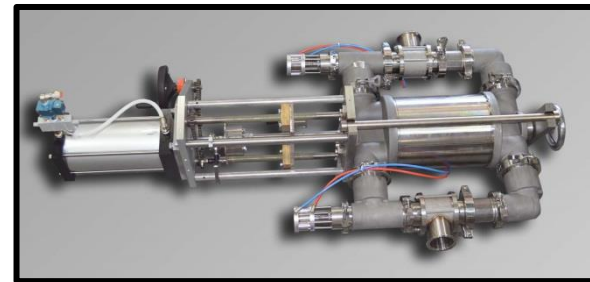

ABA-2000-PCV  
(power check  
valves)

## 1 Gallon Pumps



ABA-80 (gravity check  
valves)

## ABA-2000-GCV (gravity check valves)



ABA-99 (powered  
check valves)

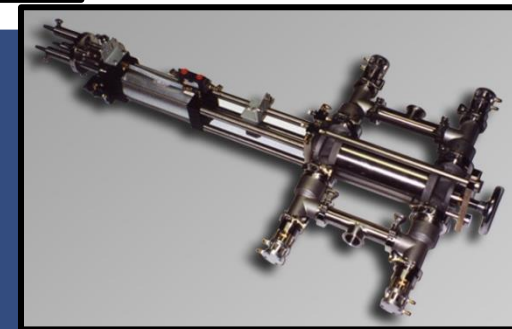

# Fill Heads

<http://www.abaltd.com/products/fill-heads.html>



Anthony Barber Associates, Ltd.

We supply 3 different kinds of fill heads for a variety of applications.



Cone Style

**\*\*NEW\*\***

A new cone style fill head, ABA-COV-85B0 features air shear or NO2 blanket technology. Forced air helps to blow off, or shear, a high viscosity product when the fill is completed. (photo on the left)

We now offer 2 stage fill heads which open fully at the beginning of a fill, close to dribble near the end, and then close completely when the fill is done.

<https://youtu.be/wpc4vLawj6Q> (photo on right)



Direct Flow

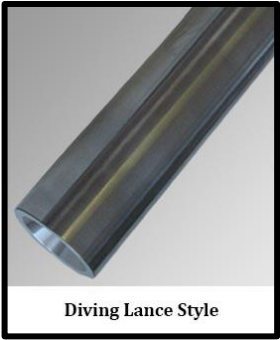

Diving Lance Style



# Accessories

<http://www.abaltd.com/products/accessories.html>



## Rotary Tables

ABA offers both in-feed and out-feed rotary tables to help speed up the filling line

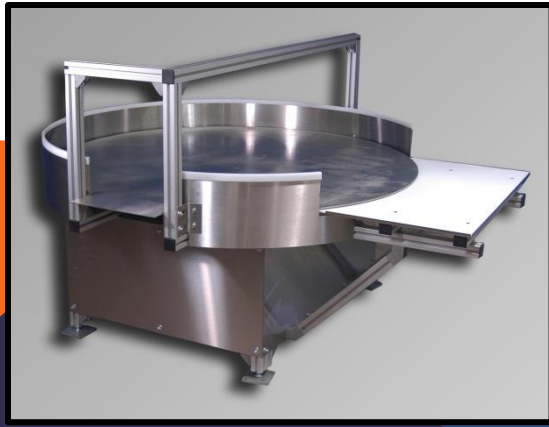

## Top Off Systems



ABA-TOPOFF is a spray nozzle based top off system which sprays a small amount of water, glycol, or other anti-skimming agent into filled product containers.

<https://youtu.be/hcOzyBmbOd8>



ABA-TOPOFF-COV-100 is a topoff system featuring our cone style fill head to deposit anti-skimming agents such as water or glycol onto the surface of the liquid. The fill head allows for a more gentle release to prevent breaking the surface of the liquid. <https://youtu.be/nK-F-JM1m8>

# Spare Parts

ABA supplies spare parts for our machines as well as Thiele, Neumo, and Neupak. Please check our website for a full selection.

<http://www.abaltd.com/parts.html>

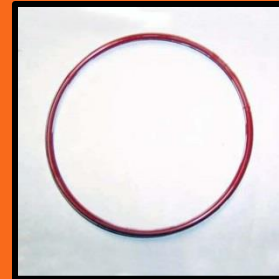

# Our Online Customer Center

<http://abaltd.com/service-and-support/client-login.html>

From here, our customers can:

- View a list of products/parts they have purchased from us
- View and download product manuals
- View complete bills of materials of products

